

# 6 - 25 Ton Unitary Split Systems Indoor

Unit Overview	
Model	TWE18043BAA**A000000000000000 00000000000000
Unit Tonnage	15 Tons
Max A.H. Operating weight	729.0 lb
Min A.H. Operating weight	675.0 lb
Unit Voltage	208-230/60/3
Refrigeration Circuit	Dual Circuit



Fan Information	
Airflow	6000 cfm
External Static Pressure	0.500 in H2O
External Plus Component Static Pressure	0.500 in H2O
Supply fan motor RPM	739 rpm
Supply fan motor BHP	2.16 bhp

Cooling Information	
Airflow	6000 cfm
Cooling EDB	80.00 F
Cooling EWB	67.00 F
Ambient Temperature	95.00 F

Heating Information			
Heat Pump Information		Electric Heat Information	
Heating EDB	70.00 F	Heating EDB	70.00 F
Heating Ambient DB	17.00 F	Electric heat capacity	0.00 kW
Heating Ambient WB	15.00 F	Electric heat delta T	0.00 F

Electrical Information			
External Static Pressure	0.500 in H2O	External Plus Component Static Pressure	0.500 in H2O
MCA - A.H.	12.00 A	MCA - A.H. for 230V w/elect. heat	12.00 A
MOP - A.H.	20.00 A	MOP - A.H. for 230V w/elect. heat	20.00 A
Evaporator Motor FCA	9.40 A		

## Refrigerant Information

These cut sheets are for reference only. Stock model numbers may differ. Contact your salesperson for job specific submittals for engineer approval.

**NOTES:**

1. PANEL DEPTH 1/2" (TYP ALL PANELS).
2. REMOVABLE DRAIN PAN AND ATTACHED DRAIN CONNECTION MAY BE INSTALLED ON END OF UNIT IN EITHER THE VERTICAL OR HORIZONTAL CONFIGURATION, PLASTIC DRAIN PAN ACCESS PLATE ON THE END OF UNIT OPPOSITE DRAIN CONNECTION MUST BE REMOVED TO SLIDE DRAIN PAN OUT OF UNIT FOR CLEANING. ACCESS PLATE MUST BE RE-INSTALLED AFTER SLIDING DRAIN PAN BACK INTO UNIT.
3. IF PERIODIC DRAIN PAN CLEANING IS REQUIRED, ALLOW ROOM FOR PARTIAL REMOVAL OF DRAIN PAN CONNECTION AT END OF UNIT.
4. 1" FEMALE SCHED. 40 PVC PIPE DRAIN CONNECTION VERTICAL CONFIGURATION.
5. 1" FEMALE SCHED. 40 PVC PIPE DRAIN CONNECTION HORIZONTAL CONFIGURATION.

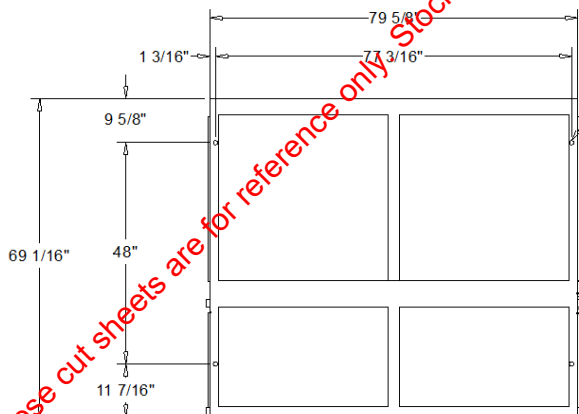
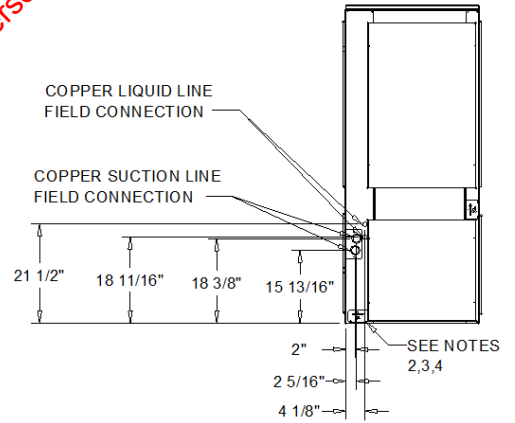
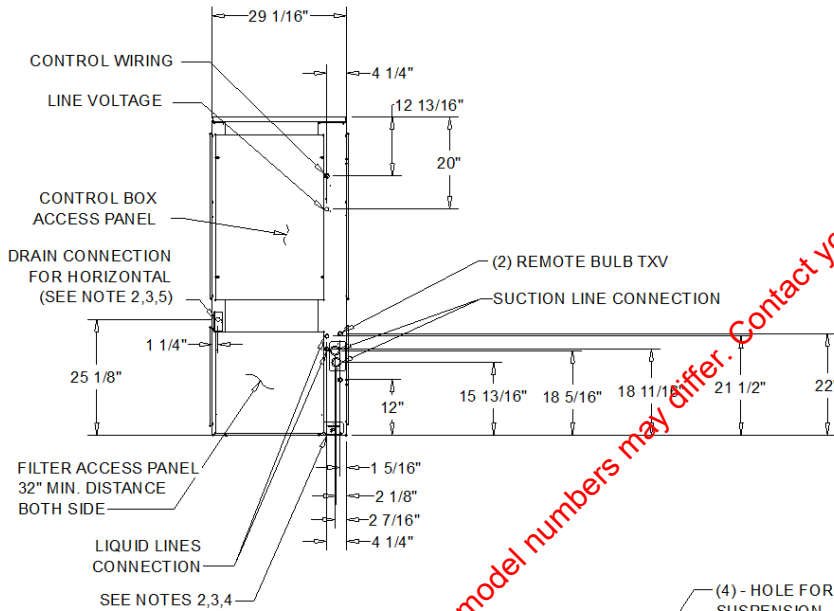
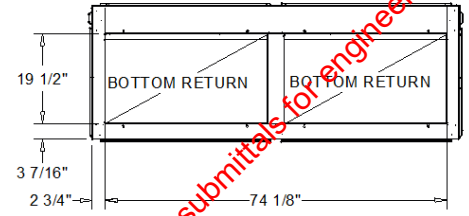
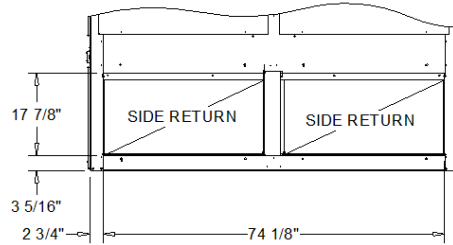
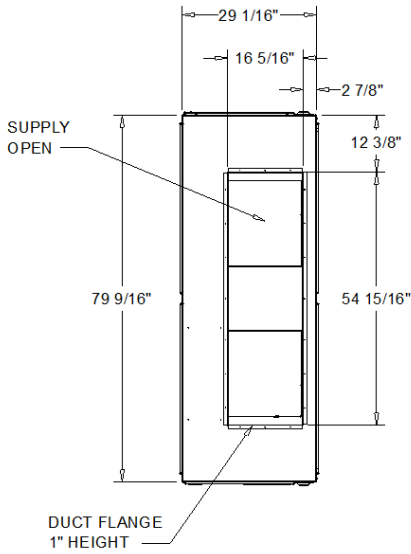

(4) - HOLE FOR HORIZONTAL SUSPENSION

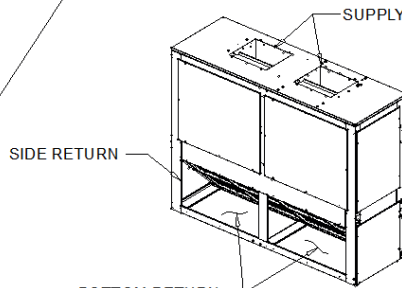

SUPPLY VERTICAL - RETURN HORIZONTAL / RETURN VERTICAL

(4) HOLE FOR HORIZONTAL SUSPENSION

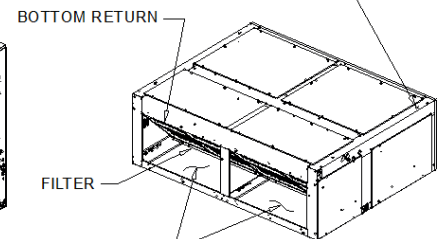

SUPPLY HORIZONTAL - RETURN VERTICAL / RETURN HORIZONTAL

**12.5 -15 TON AIR HANDLER (DUAL CIRCUIT)**

DIMENSIONAL DRAWING

These cut sheets are for reference only. Stock model numbers may differ. Contact your salesperson for job specific submittals for engineer approval.

### AIR HANDLER ELECTRICAL DATA

<b>ELECTRICAL DATA</b> Model: TWE180      Convertible 460 Voltages Unit Operating Voltage: 187-253      TWE180 Minimum Circuit Ampacity: 12.0      414-506 Maximum Fuse Size: 20.0      15.0 Maximum Circuit Breaker: 20.0      15.0		<b>EVAPORATOR FAN MOTOR (9)</b> Convertible 460 Voltages No.: 1      1 Volts: 208-230      460 Phase: 3      3 Motor HP: 3.0      3.0 Amp-FLA: 9.4      4.6 Amp-LRA: 74.9      39.3	
<b>GENERAL DATA</b>			
<b>SYSTEM DATA</b> No. Refrigerant Circuits: 2 Suction Line (in.) OD: 1 3/8" Liquid Line (in.) OD: 1/2"		<b>INDOOR COIL - TYPE</b> Tube Size: 3/8" Face Area: 16 5/16" Row/FPI: 4 / 14 Refrigerant Control: EXPANSION VALVE Drain Connection Size: 1" PVC	
<b>INDOOR FAN</b> Type: CENTRIFUGAL No. Used/Diameter x Width: 2 / 15"X15" Drive Type/No. Speed: BELT / ADJUSTABLE CFM: 6000 No. Motor: 1 Motor HP - Standard/Oversized: 3.0 / 5.0 Motor RPM: 1728 / 1750 Motor Frame Size: 56HZ		<b>FILTER</b> Type: THROUGHWAY Furnished: YES No. Size Recommended: (9) 15"X20"X2"	
<b>HEATER DATA</b>			
<b>ELECTRICAL DATA</b> Heat Rating (kW): Control Stages: Power Supply: Minimum Circuit Ampacity: Maximum Fuse Size: Maximum Circuit Breaker:		Notes: 1. KW ratings are at: 208/240V for 208-230V air handlers 200V for 460V air handlers 600V for 575V air handlers For other than rated voltage, capacity = ( $\frac{\text{Voltage}}{\text{Rated Voltage}}$ ) x 2 Rated Capacity 2. Any power supply and circuits must be wired and protected in accordance with local electrical codes. 3. The HACR circuit breaker is for U.S.A. installations only. 4. With motor field converted to 460V.	

**NOTES:**

- Cooling performance is rated at 95 F ambient, 80 F entering dry bulb, 67 F entering wet bulb.
- Gross capacity does not include the effect of fan motor heat. AHRI capacity is net and includes the effect of fan motor heat. Ratings shown are tested and certified in accordance with AHRI Standard 340/360 or 365 certification program.
- Condensing Unit Only Gross Cooling Capacity rate at 45 F saturated suction temperature and at 95 F ambient.
- AHRI Net Cooling Capacity is calculated with matched blower coil and 25 ft. of OD interconnecting tubing. EER is rated at AHRI conditions and in accordance with DOE test procedures.
- Integrated Part Load Value is based on AHRI Standard 340/360 or 365. Units are rated at 80 F ambient, 80 F entering dry bulb, and 67 F entering wet bulb at AHRI rated CFM.
- Sound Rating shown is tested in accordance with AHRI Standard 270.
- Refer to refrigerant piping program for line sizing and line length.
- Refrigerant (operating) charge is for condensing unit (all circuits) with matching blower coils and 25 ft. of interconnecting refrigerant lines. All units are shipped with a small nitrogen holding charge only.
- Second Column data Coverable to 460 volt

These cut sheets are for reference only. Check model numbers may differ. Contact your salesperson for job specific submittals for engineer approval.

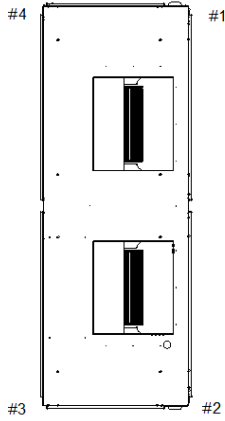

**WEIGHTS AND CORNER WEIGHTS**

Shipping:	752.0 lb
Net	675.0 lb
<b>VERTICAL</b>	
Corner 1:	167.0 lb
Corner 2:	192.0 lb
Corner 3:	181.0 lb
Corner 4:	135.0 lb
<b>HORIZONTAL</b>	
Corner A:	196.0 lb
Corner B:	163.0 lb
Corner C:	145.0 lb
Corner D:	171.0 lb

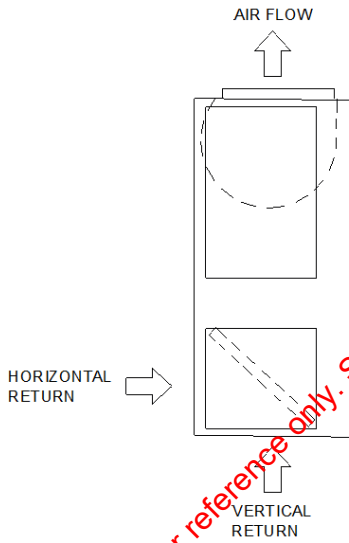
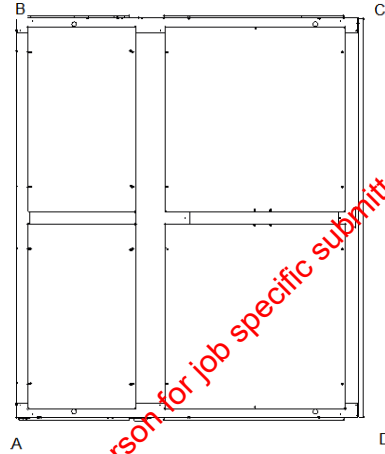

VERTICAL APPLICATION

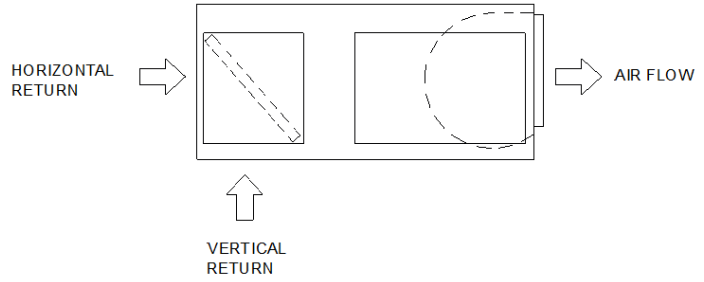

HORIZONTAL APPLICATION

**WEIGHTS AND LOAD POINT LOCATION FOR CONDENSOR**

WEIGHT AND RIGGING

These cut sheets are for reference only. Stock model numbers may differ. Contact your salesperson for job specific submittals for engineer approval.

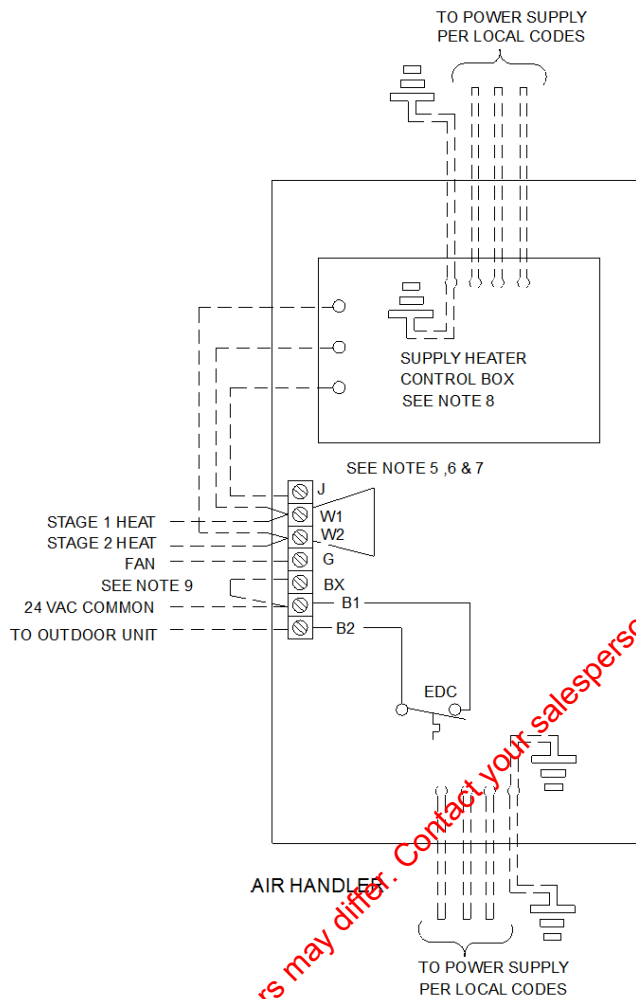

INTER-COMPONENT WIRING

	}	24 VOLT	FACTORY WIRING
		LINE VOLT	
	}	24 VOLT	FIELD WIRING
		LINE VOLT	

NOTES:

1. POWER WIRING AND GROUNDING OF EQUIPMENT MUST COMPLY WITH LOCAL CODES.
2. BE SURE POWER SUPPLY AGREES WITH EQUIPMENT NAMEPLATE.
3. LOW VOLTAGE WIRING TO BE 18 A.W.G. MINIMUM CONDUCTOR.
4. USE COPPER CONDUCTORS ONLY.
5. IF TWO STAGE ELECTRIC HEATERS AND THERMOSTAT ARE USED, REMOVE JUMPER BETWEEN W1 AND W2 .
6. FOR SINGLE STAGE ELECTRIC HEATER, OMIT WIRE BETWEEN W2 AND THERMOSTAT AND W2 AND ELECTRIC HEATER.
7. FOR COOLING ONLY, OMIT WIRES BETWEEN W1,W2 AND THERMOSTAT AND OMIT ELECTRIC HEATER.
8. WHEN ELECTRIC HEATER ACCESSORY IS USED SINGLE POINT POWER ENTRY OR DUAL POINT POWER ENTRY IS FIELD OPTIONAL. SINGLE POINT POWER ENTRY OPTION IS THROUGH ELECTRIC HEATER ONLY.
9. WHEN ELECTRIC HEATER ACCESSORY IS USED, A FIELD SUPPLIED JUMPER MUST BE PLACED BETWEEN "B1" AND "BX" ON THE THE INDOOR SECTION LOW VOLTAGE TERMINAL BOARD.

These cut sheets are for reference only. Stock model numbers may differ. Contact your salesperson for job specific submittals for engineer approval.

### General - TWE

Completely Factory Assembled Convertible for Horizontal or Vertical Configuration Convertible for Cooling Only or Heat Pump Application Convertible for Left or Right External Connections (Refrigerant and/or Electrical) Convertible for Front or Bottom Air Return Nitrogen Holding Charge Certified and Rated in Accordance with AHRI and DOE Standards Certified to UL 1995 for Indoor Blower Coil Units

### Casing - TWE

Zinc Coated, Heavy Gauge, Galvanized Steel Weather Resistant Baked Enamel Finish Access Panels with Captive Screws Completely Insulated with Foil Faced, Cleanable, Fire Retardant, Permanent Odorless Glass Fiber Material Captured or Sealed Insulation Edges Electrical Connection Bushings or Plugs Refrigerant Connection Bushings or Plugs Withstand Elevated Internal Static Pressure

### Refrigeration System - TWE

Single or Dual Circuit Distributor(s) Thermal Expansion Valves (TXVs)

### Evaporator Coil - TWE

3/8" Internally Enhanced Copper Tube Mechanically Bonded to Lanced Aluminum Plate Fins Factory Pressure and Leak Tested to 449 psig. Draw-Through Airflow Dual Circuits Are Interlaced/Intertwined Double Sloped, Removable, Cleanable, Composite Drain Pan Four Drain Pan Positions

### Indoor Fan - TWE

Double Inlet, Double Width, Forward Curved, Centrifugal Type Fan Dual Fans On 10.4-20.912.5-25 Ton Air Handlers Adjustable Belt Drive Permanently Lubricated Bearings

### Indoor Motor - TWE

Adjustable Motor Sheaves Fixed Motors Sheaves (S/VAV and 2-Speed VFD) Thermal Overload Protection Permanently Lubricated Bearings Meet Energy Policy of 1992 (EPACT) Optional Over Sized Motors for High Static Applications

### Controls - TWE

Completely Internally Wired Numbered and Colored Wires Magnetic Indoor Fan Contractor Low Voltage Terminal Strip Single Point Power Entry Evaporator Defrost Control

### Filters - TWE

Access From Side Coil Panels Filters Slide on Rack One Inch (1"), Throw-Away Filters on 4.6-8.335-10 Ton Units Filter Rack Convertible to Two Inch (2") Capability on 5-10 Ton Units Two Inch (2"), Throw-Away Filters on 10.4-20.912.5-25 Ton Units

### Electric Heaters TWE

Heavy Duty Nickel Chromium Elements cETL Approved Installs Directly On Fan Discharge One or Two Stage Control (Dependent Upon Capacity) Single Point Power Entry Terminal Strip Connections 208-230V Heaters Internally Wye Connected Automatic Line Break High Limit Controls 230V Heaters Internally Delta Connected Automatic Reset of High Limit Controls Through Pilot Duty with Secondary Backup Fuses Links

# Condenser and Air Handler Pairings

**Table 3. Model number descriptions**

TWE Air Handler with Symbio
<p><b>Digit 15 – Controls</b></p> <p><b>1</b> = Constant Volume  <b>C</b> = 2 Stage Airflow (Electromechanical Condenser Only)  <b>D</b> = 2 Stage Airflow/Single Zone VAV (Symbio Condenser Only)</p>
TWE Air Handler (pre-Symbio)
<p><b>Digit 15 – Controls</b></p> <p><b>0</b> = Constant Volume  <b>A</b> = 2 Stage Airflow (Electromechanical Condenser Only)  <b>B</b> = Single Zone VAV (ReliaTel Condenser Only)</p>

**Table 4. Condenser and air handler pairing instructions (See document SS-SVN016A-EN)**

Condenser (model # digit)	Air Handler		Instructions
	Type	Supply Fan Type (model # digit)	
Odyssey Electromechanical (Digit 15 = E)	Odyssey Symbio	Constant Volume (Digit 15 = 1)	Pairing F, D or G require wire harness kit WIR010190 (required) and WIR010185 (optional) to connect Air Handler Relay Board to VFD.
		2-Speed Airflow (Digit 15 = C)	
		Single Zone VAV (Digit 15 = D)	
Odyssey ReliaTel (Digit 15 = R)	Odyssey Symbio	Constant Volume (Digit 15 = 1)	Pairing F, D or G require wire harness kit WIR010190 (required) and WIR010185 (optional) to connect Air Handler Relay Board to VFD.
		2-Speed Airflow (Digit 15 = C)	
		Single Zone VAV (Digit 15 = D)	

These cut sheets are for reference only. Stock model numbers may differ. Contact your salesperson for job specific submittals for engineer approval.

# Condenser and Air Handler Pairings

**Table 4. Condenser and air handler pairing instructions (continued) (See document SS-SVN016A-EN)**

Condenser (model # digit)	Air Handler		Instructions
	Type	Supply Fan Type (model # digit)	
Odyssey Symbio (Digit 15 = S)	Odyssey Symbio	Constant Volume (Digit 15 = 1)	Install a shielded, twisted pair cable if the Air Handler has Electric Heat and/or requires Single Zone VAV operation (Trane IMC communication)
		2-Speed Airflow (Digit 15 = C)	Pairing G, H, and 2 will not have heat in defrost.  Pairing G, H, and 2; electric heat will not operate if zone sensor installed, only with a thermostat  Install a shielded, twisted pair cable if the Air Handler has Electric Heat and/or requires Single Zone VAV operation (Trane IMC communication)
		Single Zone VAV (Digit 15 = D)	Install a shielded, twisted pair cable if the Air Handler has Electric Heat and/or requires Single Zone VAV operation (Trane IMC communication)  Install a shielded, twisted pair cable for Symbio Condenser control of the Air Handler supply fan VFD (Modbus communication)
	Odyssey Electromechanical	Constant Volume (Digit 15 = 0)	Pairing G, H, and 2 will not have heat in defrost.
		2-Speed Airflow (Digit 15 = A)	Pairing G, H, and 2; electric heat will not operate if zone sensor installed, only with a thermostat.
	Odyssey ReliaTel	Variable Speed, Single Zone VAV (Digit 15 = B)	Pairing G, H, and 2 will not have heat in defrost.  Pairing G, H, and 2; electric heat will not operate if zone sensor installed, only with a thermostat.  Install a shielded, twisted pair cable for Symbio Condenser control of the Air Handler supply fan VFD (Modbus communication)
			Pairing G, H, and 2; electric heat will not operate if zone sensor installed, only with a thermostat.
			Pairing F, D or G require wire harness kit WIR010190 (required) and WIR010185 (optional) to connect Air Handler Relay Board to VFD.  This pairing requires the replacement of the RTOM module with a Symbio Relay Board (MOD03105) and that the VFD wires 81B, 82B, 93B, 94B and 94D be replaced with wire harness kit WIR010190 (required) and WIR010185 (optional). The Air Handler will operate as a 2-speed fan.
	Generic Air Handler	Constant Volume	
	Two Symbio Condensers (2 condensers to 1 air handler)	Odyssey Electromechanical	

These cut sheets are for reference only. Stock model numbers may differ. Contact your salesperson for job specific submissions for engineer approval.